

Blockchain Voting System

Miss. Raut Chaitali N¹, Miss. Kshirsagar Samruddhi N², Mr. Dumre Akshay R³,
Mr. Kote Vishal B⁴, Prof. Shaikh S.F.⁵

^{1,2,3,4}Diploma Student, ⁵Head of Department
Department Of Computer Engineering
S.N.D. Polytechnic, Yeola

Abstract

Building a secure electronic voting system that offers the fairness and privacy of current voting schemes, while providing the transparency and flexibility offered by electronic systems has been a challenge for a long time. In this work-in-progress paper, we evaluate an application of blockchain as a service to implement distributed electronic voting systems. The paper proposes a novel electronic voting system based on blockchain that addresses some of the limitations in existing systems and evaluates some of the popular blockchain frameworks for the purpose of constructing a blockchain-based e-voting system. In particular, we evaluate the potential of distributed ledger technologies through the description of a case study; namely, the process of an election, and the implementation of a blockchain-based application, which improves the security and decreases the cost of hosting a nationwide election.

Keywords: Blockchain, Electronic Voting System and E-voting.



Published in IJIRMPS (E-ISSN: 2349-7300), Volume 12, Issue 1, Jan. - Feb 2024

License: [Creative Commons Attribution-ShareAlike 4.0 International License](https://creativecommons.org/licenses/by-sa/4.0/)



INTRODUCTION

The use of technology has become important at this point in helping to meet human needs. Due to the increasing use of technology, new challenges are brought in the process of democracy as most people today don't trust their governments, making elections is very important in modern democracy. Elections have a great importance in determining who will rule a nation or an organization or it can be said as it is an event that decides the fate of any nation. In modern democracy, elections are very important but large sections of society around the world do not trust their election system which is a major concern for democracy. Even the world's largest democracies like India, United States, still suffer from a flawed electoral system. Vote rigging, hacking of EVM (Electronic voting machine), election manipulation, and polling booth capturing are the major issues in the current voting system.

The blockchain is said as emerging, decentralized, and distributed technology that promises to enhance different aspects of many industries. Expanding e-voting into blockchain technology could be the solution to eliminate the present concerns in e-voting system. There is no doubt that the ever changing concept of the blockchain, which is the backbone of the famous cryptocurrency Bitcoin has triggered the start of a new era in the Internet and the online services. While most people focus only on bitcoin and other cryptocurrencies; there are in fact, many operations, both administrative and fintech that can only be done online/offline can now safely be moved to the Internet as online services because of immutability of blockchain. What makes

blockchain a powerful tool is its smart contracts and many features which overcome traditional systems.

Smart contracts are meaningful pieces of codes, to be integrated in the blockchain and executed as scheduled in every step of blockchain updates. E-voting, is another trending, yet critical, topic related to the online services. The blockchain with the smart contracts, emerges as a good candidate to use in developments of safer, cheaper, more secure, more transparent, and easier-to-use e-voting systems.

1. PURPOSE

Elections are a fundamental pillar of a democratic system enabling the general public to express their views in the form of a vote. Due to their significance to our society, the election process should be transparent and reliable so as to ensure participants of its credibility. Within this context, the approach to voting has been an ever-evolving domain. Blockchain is one of the emerging technologies with strong cryptographic foundations enabling applications to leverage these abilities to achieve resilient security solutions.

EXISTING SYSTEM

1. Electronic voting has been an area of research focus for many years by using computing machines and equipment for casting votes and producing high quality and precise results in accordance with the sentiments of the participating voters.
2. Initially computer counting system allowed the voter to cast vote on papers.
3. If the voting system is well understood by the voters, the system's usability can be increased remarkably.

OBJECTIVE OF SYSTEM

1. Secure E Voting System
2. To make such a system which will be easy to use and more user friendly for our customer.
3. Centralized management system
4. To build an online system this would enable voters to cast their votes on chosen candidates.
5. Study and implement a security method to be used to ensure that votes being cast in the system will not be compromised and any outside attack.

LITERATURE SURVEY

"A Visionary Approach to Smart Voting System" a paper of Rohit Sroa. A paper states that with the emergence of COVID-19 as a global pandemic, the need for an online voting system is becoming appallingly evident in India. Unfortunately, India still suffers from a flawed electoral system in today's scenario. Ballot rigging, hacking of the EVM (Electronic voting machine), election manipulation, and polling booth capturing are the significant issues in this voting system. To avert such a costly predicament in the future, many countries are currently experimenting with blockchain-based voting systems. However, there are also significant drawbacks to this method. Consequently, our paper proposes a novel online voting system based on hash graph technology. The hash graph encryption method is a superior version of blockchain encryption and eradicates a few drawbacks of blockchain. This system preserves participant's anonymity while still being open to public inspection. Voters are authenticated using their Voter ID, Aadhaar Card Number, and face recognition. Furthermore, JWT Authentication is implemented to enhance the security of the login portal. Additionally, the voters can also assure their cast vote using the highly encrypted unique ID generated by our system. Besides that, the voter data is stored in a highly secured database. Furthermore, homomorphic encryption is used to store the votes and assist in counting the vote securely. Finally, it is also equipped with a chatbot that works as a support to the voters. In conclusion, this

paper presents an in-depth evaluation of the scheme that successfully demonstrates its effectiveness in achieving an end-to-end verifiable online voting system.

“Aadhar Based Electronic Voting System And Providing Authentication on Internet Of Things” is a paper of Dr.V.Latha. A paper present the Flawless voting is ensured by Electronic voting machine. People should believe that their vote is secured and there is no malpractice. The main aim of this project is to develop a secure Electronic voting machine using Finger print identification method, for finger print accessing we use AADHAR card database. At the time of voting in the elections, the e-voting process authentication can be done using finger vein sensing, which enables the electronic ballot reset for allowing voters to cast their votes. Also the voted data and voter’s details can be sent to the nearby Database Administration unit by using WIFI System. The finger print scanning is used to ensure the security to avoid fake, repeated voting etc. It also enhances the accuracy and speed of the process. The purpose of such system is to ensure that the voting rights are accessed only by a legitimate user and no one else. During elections, the thumb impression of a voter is entered as input to the system. This is then compared with the available records in the database. If the particular pattern matches with anyone in the available record, access to cast a vote is granted. But in case the pattern doesn’t match with the records of the database or in case of repetition, access to cast a vote is denied or the vote gets rejected.

“Finger Print Based Smart Voting System” is a paper of Ms.Mary Varsha Peter. It state that, The main objective of this project is to enable safe and secure voting system and is to avoid misconceptions which take place in election period. Voting System helps to choose their government and also the political representatives. It also ensures that to avoid fake and repeated vote during election. In this project the finger print is given as input. All the database of the voter include their finger print, photo, mobile number etc has been stored in the MATLAB. If the finger print enrolled by the voter should be matched with the database, It enables the voter to enroll his/her vote. If the finger print doesn’t match the system will lock the process. The important is that the voter can enroll their vote at their desire location. And also the number of vote enrolled should be updated in the database administration unit every time after voting is done. The smart voting system will enhance better accuracy and high-speed process. Through this voting system the disadvantages which are in the electronic voting system should be overcome.

PROPOSED SYSTEM

Our Indian government gave us right to elect their desired leader. For controlling and conducting this election process, the government formed a separate commission named Election Commission of India. This commission should not support and favorable to any of the political leader or the party and also it work as per the rules given in law. The election commission will follow the technique named Electronic Voting Machine in which the voter should produce the election id card provided by the commission and it has been verified with the official database list. After this process only, the voter can poll their vote. This will not leads to time consuming and less man power. But in our project, it has less manual power and time consuming. Also it is safer than the old voting process. The disadvantages in EVM is that the counting of vote and result display will take number of days and also the candidate should enroll their vote at their allocated location only. This makes less accuracy of voting. But our project enable the candidate can enroll their vote at their desired location or at from working place. So this leads 100% accuracy of voting.

SYSTEM ARCHITECTURE

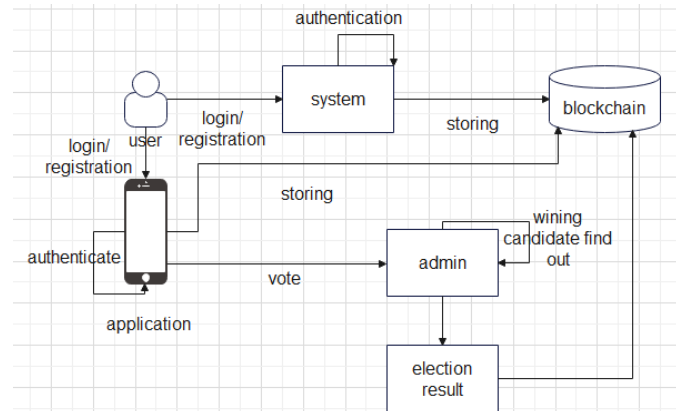

Fig -1: System Architecture Diagram

IMPLEMENTATION DETAILS

Election is the one of the most important thing which binding our nation together to elect our leader till the next election. In the previous system, the polling officer is the in-charge of the control of the election process until the close button is pressed. In this process it will consume more manual work and it is not secure. The discrepancy should be noticed only through the balloting unit during the counting of votes. The problem associated with this electronic voting machine is that during election time the candidate should go to their allocated location for enroll their vote. Due this problem many of them were didn't like to vote. This create many malpractice during election.

ADVANTAGES

- Providing the preventive measures system for voting.
- It completely rules out the chance of invalid votes.
- Its use results in reduction of polling time.
- Results in fewer problems in electoral preparations, law and order candidates' expenditure.
- It is capable of saving considerable printing stationery and transport of large volumes of electoral material.

APPLICATION

To develop a secured electronic voting system using fingerprint biometric techniques that would tackle all the drawbacks presented in this project and satisfy e-voting functional and security requirements towards achieving credible elections at all levels.

MATHEMATICAL MODEL

System Description:

$$S = (I, O, F)$$

Where,

S: System.

I = {UI, AD, FS} are set of Inputs

Where,

UI: User Id Login

AD: Aadhar Data

FS: Finger print Scan

$F = \{A, P\}$ are set of Function

Where,

A: Authentication

P: processing

$O = \{N, U\}$ are set of Output

Where,

N: Notification

V: Vote

Success Conditions:

Proper database, Scanning

Failure Conditions:

No database, internet connecti

CONCLUSION

Hence in the proposed framework, we have tried to build a secure voting system that is free from unauthorized access while casting votes by the voters. The server aspects of the proposed system have such distribution of authority that server does not enable to manipulate the votes. It is expected that the proposed voting system will increase the transparency and reliability of the existing electoral system

REFERENCES

- [1] Blockchain Based E-Voting System, May 2021 International Journal of Scientific Research in Science and Technology, Prof. Mrunal Pathak, Amol Suradkar, Ajinkya Kadam, Akansha Ghodeswar
- [2] E-voting systems: A tool for e-democracy, January 2010 Knowledge Management Research Practice 2(3):264-274, Emad Abu-Shanab, Michael B. Knight
- [3] Science and Information Conference 2015 July 28-30, 2015 — London, UK 1365 — P a g e www.conference.thesai.org, A Secure e-Government's e-Voting System, Mohammad Hosam Sedky, Essam M. Ramzy Hamed
- [4] E-Voting System Based on Blockchain Technology: A Survey, Sarah Al-Maaitah; Mohammad Qatawneh; Abdullah Quzmar, 2021 International Conference on Information Technology (ICIT) IEEE 2021
- [5] International Journal of Trend in Research and Development, Volume 2(5), ISSN 2394-9333 www.ijtrd.com IJTRD — Sep - Oct 2015 Available Online @ www.ijtrd.com 438, Student Online Voting System, Raja Lakshmi, Meenakshi Nivya and K S Selvanayaki.